



PRODUCT CODE

IS6020

DESCRIPTION

A medium duty magnetic meeting stile seal.

APPLICATION

The IS6020 magnetic seal is designed to be fitted to existing timber door leaves on double swing doors and sliding door meeting stiles.

KEY FEATURES

- Fully mortised, aesthetic design.
- Positive seal with excellent closing strength where latches may not be required.
- Easily installed without removing the door.

USE WITH

Used in conjunction with a Lorient Integrity™ 8000 series automatic door bottom seal and a 4000 series threshold plate to provide a total door sealing solution.

MATERIALS

An extruded and anodised aluminium profile combined with a flexible PVC gasket, complete with magnet.

GAP SIZE

Minimum 5mm - Maximum 7mm

SIZES

Standard Lengths 2250mm
Also available in 250mm increments: 1000mm to 3000mm
Seals can be cut on-site for exact dimensions.

FINISH

- Silver anodised aluminium with grey PVC gasket.
- Bronze anodised aluminium with black PVC gasket.

FIXING

The aluminium carrier is toothed and splayed to lock into a 16.5mm x 12mm groove. The magnetic seals are also 'locked' in to prevent creeping. (This seal is not recommended for highly active doors.)

APPROVAL/S

- Acoustic ratings to AS1191 and AS1276 in conjunction with other Lorient Integrity™ seals.

SPECIFICATIONS

Lorient Integrity™ IS6020 fitted to the meeting stile of the door leaf.

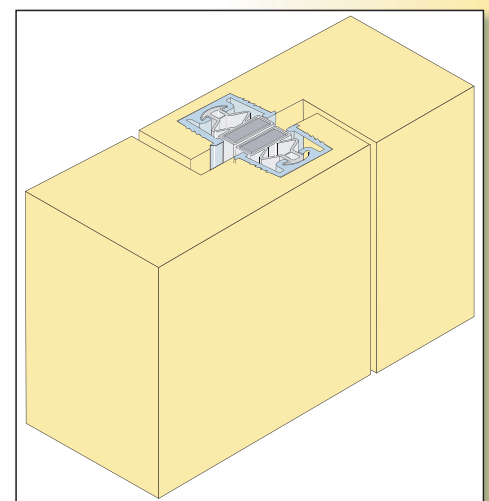
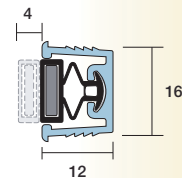

Above: Rebated meeting stile detail.

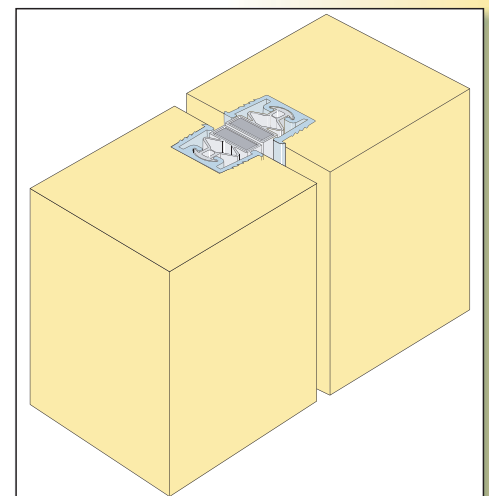

Above: Meeting stile detail for double swing doors.

Lorient reserves the right to alter published data or make products obsolete without prior notice.

Please contact our office if you require any further information

Head Office Ph: (07) 3635 5000 Fax: (07) 3861 9266

Toll Free 1300 858 010

E-mail sales@lorient.com.au www.lorient.com.au

Datasheet D-017-06/09. All measurements in mm. Copyright © 2009 Lorient Australia.