

# IS8035si

## Fitting Instruction

Automatic Door Bottom Seal

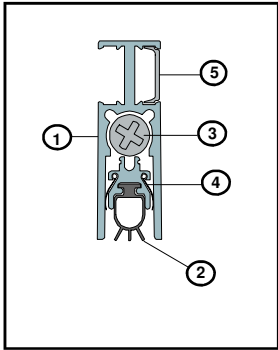

Length:

### DESCRIPTION OF CONTENTS

- Aluminium Housing (1)
- Silicone Gasket (2)
- Actuator Button (3)
- Smoke Fins (4)
- Flexible Cover Strip (5)
- Bag containing
  1. 2 x End caps
  2. Fixing Screws
  3. 1 x Striker Button
- Fitting Instructions

### TOOLS REQUIRED FOR INSTALLATION

- Tape Measure
- Saw (Power or Hand)
- Screw Driver
- 4mm Drill Bit
- 2.5mm Drill Bit
- Drill (Power or Hand)
- Knife
- Pencil or Marker
- Router
- Cutting Router Bit

### FACE FIXED INSTALLATION

#### STEP 1

Remove the seal from the packaging and remove the flexible cover strip.

#### STEP 2

**WARNING:** Check maximum cut back lengths on the table provided.

Measure the distance between the door stops. Pull back the gasket from the **opposite** end to the actuator button and using a power saw/hacksaw, cut the aluminium sections to the measured length, less 8mm for end caps and clearance. Remove cutting swarf.

Push gasket back into position and cut to length with a sharp knife.

#### STEP 3

Fit the end cap to the actuator button end and position the seal at the bottom face of the door on the stop side, button end tight up to the door stop and allowing a maximum 10mm gap (minimum 3mm) between the door bottom and the sill. Ensure the actuator button is on the hinge side.

#### STEP 4

Drill holes in aluminium housing, then pre-drill and screw fix to the door using screws provided. Cut the flexible cover strip to length and replace. Fit remaining end cap.

#### STEP 5

For timber frames, position the striker button on the stop where the actuator button meets the door frame.

#### STEP 6

Open and close the door observing the operation of the seal. Adjust accordingly by winding the actuator button clockwise to reduce movement and anticlockwise to increase the seal movement.

**NOTE:** For optimum results the seal should be adjusted so that the silicone gasket touches the sill in the final closing moment of the door.

### SEMI-MORTISED

#### STEP 1

Remove the door from its hinges and cut a 37mm deep x 13mm wide rebate into the bottom of the door (on the side of the door the seal is to be positioned) and re-hang the door.

#### STEP 2

Measure the door width. Cut the seal to the door width, using the same principles as per the face-fixed installation details.

We recommend IS8035si automatic door bottom seal be used together with a Lorient Integrity™ 7000 series perimeter seal and, if required a 4000 series threshold plate.

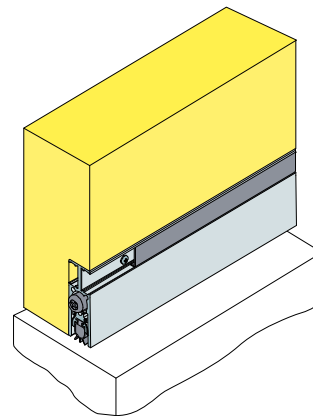

IS8035si semi-mortised

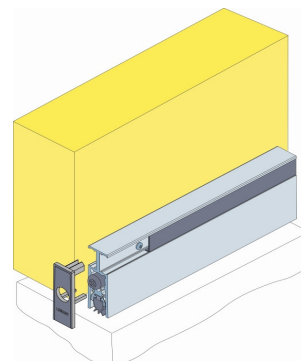

IS8035si face fixed.

### NOTE

*Recommendations as to methods for use of materials and construction details are based on the experience and knowledge of Lorient and are given in good faith as a general guide and service to designers, contractors and manufacturers.*

*Lorient reserves the right to make alterations or delete any installation detail without prior notice.*

**IMPORTANT – Ensure that the installation of this product does not impede the opening or closing of the door. It is recommended to check the adjustment of the door seal periodically to ensure the door assembly to which it is fitted, closes and latches properly.**

### CUT BACK SIZES

Do not cut the seal shorter than the lengths indicated below or this will affect the normal operation of the internal mechanism:

380mm	cuts to	275mm
600mm	cuts to	380mm
820mm	cuts to	600mm
920mm	cuts to	820mm
1070mm	cuts to	920mm
1220mm	cuts to	1070mm

### OTHER INTEGRITY™ ARCHITECTURAL SEALS INCLUDE:

- Door Perimeter Seals
- Threshold Plates
- Door Bottom Seals
- Brush Seals
- Automatic Door Bottom Seals
- Magnetic Seals

Contact your nearest Lorient office for further details.