

IS8091si

Fitting Instruction

Automatic Door Bottom Seal

WARNING

Do not cut the seal before the hand of the door or seal location has been determined.

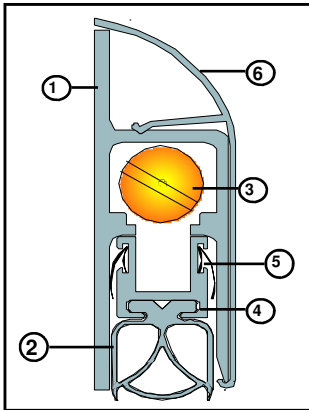

Length:

DESCRIPTION OF CONTENTS

- Aluminium Housing (1)
- Silicone Gasket (2)
- Actuator Button (3)
- Internal Carrier (4)
- Smoke Fins (5)
- Aluminium Cover Plate (6)
- Two End Caps & Plug
- Striker Button (drawing pin)
- Bag of Screws
- Fitting Instructions

TOOLS REQUIRED FOR INSTALLATION

- Tape Measure
- Saw (power or hand)
- Screw Driver
- 3mm Drill Bit
- 4.5mm Drill Bit
- Countersinking Bit
- Drill (power or hand)
- Knife
- Pencil or Marker

REVERSING

HAND OF SEAL

STEP 1

Remove the aluminium cover plate and the self-tapping screw from the front face.

STEP 2

Pulling on actuator button, remove the internal carrier from the housing (ensure not to disturb the sequence of components).

STEP 3

Replace the internal carrier into the opposite end of the housing. Ensure that the internal carrier is flush with the end of the housing at the button end.

STEP 4

Secure internal carrier by re-fixing self-tapping screw into the other hole location at the other end of the housing.

STEP 5

Check for correct operation before cutting to size.

STEP 2 Illustration

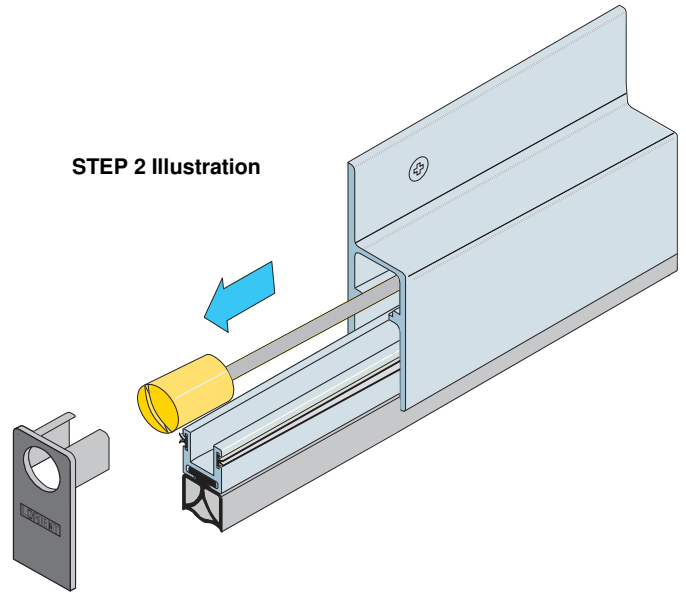

STEP 3 Illustration

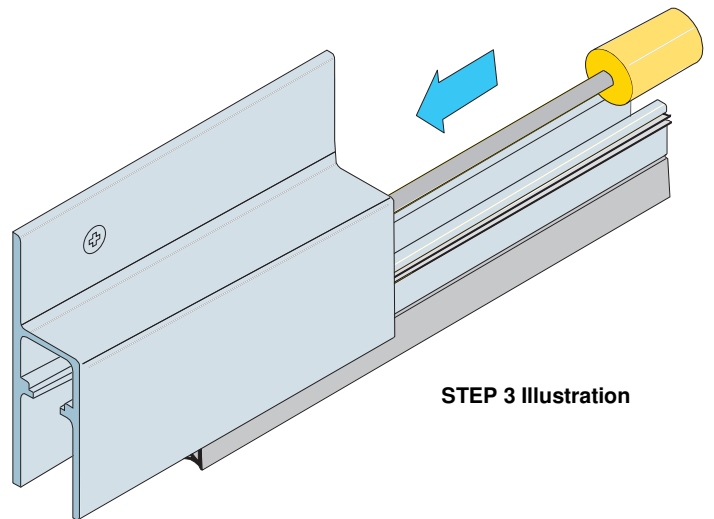

OTHER INTEGRITY™ ARCHITECTURAL SEALS INCLUDE:

- | | |
|-------------------------------|--------------------|
| ■ Door Perimeter Seals | ■ Threshold Plates |
| ■ Door Bottom Seals | ■ Brush Seals |
| ■ Automatic Door Bottom Seals | ■ Magnetic Seals |

Contact your nearest Lorient office for further details.

AUSTRALIA
Lorient Australia
Tel 1300 858 010

ASIA PACIFIC
Lorient Pacific Limited Hong Kong
Tel: (+852) 2505 0328

EUROPE
Lorient Polyproducts Ltd UK
Tel: (+44) 1626 834252

MIDDLE EAST
Lorient Middle East Building
Materials Trading LLC Dubai
Tel (+971) 4267 4339
Fax (+971) 4267 5339

WARNING

Do not cut the seal before the hand of the door or seal location has been determined.

INSTALLATION DETAIL

STEP 1

Remove seal from packaging and slide off the aluminium cover plate.

STEP 2

Measure the distance between the door stops.

STEP 3

WARNING: Check maximum cut-back lengths on the table provided.

Pull back the gasket from the **opposite** end to the actuator button and using a power saw/hacksaw, cut the aluminium sections to the measured length, less 7mm for end caps and clearance. Remove cutting swarf.

NB: When cutting the seal to length, shorten the inner carrier by a further 3mm by removing the small self tapping screw from the face of the housing and sliding the internal carrier proud of the housing. Cut to length, slide back and re-fix screw. Push gasket back into position and cut to length with a sharp knife.

STEP 4

Fit the end cap to the actuator button end and position the seal to the bottom face of the door on the stop side, button end tight up to the door stop and allowing a maximum of 15mm between the door bottom and the sill. (See Figure 1) Ensure the actuator button is on the hinge side.

STEP 5

Drill and countersink 4.5mm fixing holes in the top flange of the housing. Pre-drill and screw fix to the door using screws provided. Re-fit the aluminium cover plate and push fit the remaining end cap and plug.

STEP 6

For timber frames, position the striker button on the stop where the actuator button meets the door stop.

STEP 7

Open and close the door observing the operation of the seal. Adjust accordingly by winding the actuator button clockwise to reduce movement and anticlockwise to increase the seal movement.

NOTE: For optimum results the seal should be adjusted so that the silicone gasket touches the sill in the final closing moment of the door.

We recommend the IS8091si automatic door bottom seal be fitted with a Lorient Integrity™ 7000 series perimeter seal and a 4000 series threshold plate.

IMPORTANT – Ensure that the installation of this product does not impede the opening or closing of the door. It is recommended to check the adjustment of the door seal periodically to ensure the door assembly to which it is fitted, closes and latches properly.

NOTE

Recommendations as to methods for use of materials and construction details are based on the experience and knowledge of Lorient and are given in good faith as a general guide and service to designers, contractors and manufacturers.

Lorient reserves the right to make alterations or delete any installation detail without prior notice.

CUT BACK SIZES

Do not cut the seal shorter than the lengths indicated below or this will affect the normal operation of the internal mechanism.

450mm	cuts to	275mm
610mm	cuts to	450mm
820mm	cuts to	610mm
920mm	cuts to	820mm
1070mm	cuts to	920mm
1220mm	cuts to	1070mm
1500mm	cuts to	1220mm

Figure 1

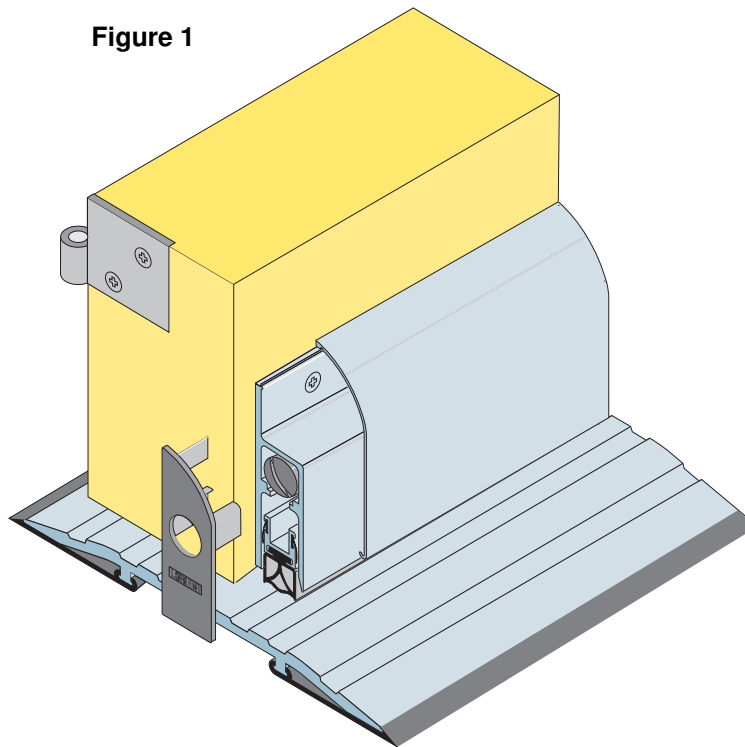

OTHER INTEGRITY™ ARCHITECTURAL SEALS INCLUDE:

- Door Perimeter Seals
- Door Bottom Seals
- Automatic Door Bottom Seals
- Threshold Plates
- Brush Seals
- Magnetic Seals

Contact your nearest Lorient office for further details.