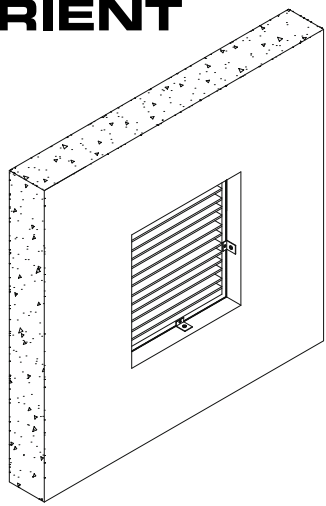

## Installation Instructions

1. Depending upon fixing bracket chosen, fasten mounting Angle Tab or Z brackets to one side of damper with steel self drilling screws or steel pop rivets).
2. Position damper centrally in penetration aperture as per system drawing
3. Fix mounting Angle Tab or Z bracket to wall aperture using masonry anchors (supplied by others).
4. Fire-stop any gaps between the damper & building element with LORIENT Intumescent Mastic (supplied separately). Ensure fill depth corresponds with those detailed in the System Drawing.
5. If connecting ductwork to wall ensure that an appropriate AS1682.2 compliant breakaway joint method is used.
6. Ensure product and certification labels are in a prominent position for easy identification during subsequent maintenance inspections.
7. Ensure convenient access is provided for visual inspection and cleaning as necessary.

## Notes

1. Product must be fitted in accordance with this detail, including the use of LORIENT Intumescent Mastic to ensure compliance with LORIENT Fire Test Approval detailed.

<b>Building Element</b>	<b>Masonry</b>
<b>Application</b>	NO casing with various fixing brackets
<b>Maximum Size</b>	600mm x >10m
<b>FRL</b>	- / 120 / -
<b>Test Reference No.</b>	CSIRO FCO1854, FCO2512
<b>System No.</b>	<b>WM11</b>