



Smoke Sealing Solutions

Solution for Smoke Doors ('deemed to satisfy' BCA Specification C3.4)

Double Leaf / Double Swing

IS7070si / IS7070si / LP4204TF

Description

IS7070si perimeter seal - slim-line perimeter & astragal seal with twin-finned, high performance silicone gaskets.

LP4204TF door bottom seal - combined intumescent fire & smoke seal, retrofitted to the door bottom providing excellent smoke & acoustic properties.

Application

This sealing combination suitable for typical pivot type smoke doors requiring seals to withstand smoke at 200°C for 30 minutes, as per the Building Code of Australia, Specification C3.4 for 'smoke doors'.

2 layers of the IS7070si seal are rebated to the head, stiles & meeting stiles, bypassing the door hardware.

The LP4204TF seal is fitted to the underside of the door, checked to allow for the pivot hardware without cutting the external fins, ensuring a continuous smoke seal is achieved.

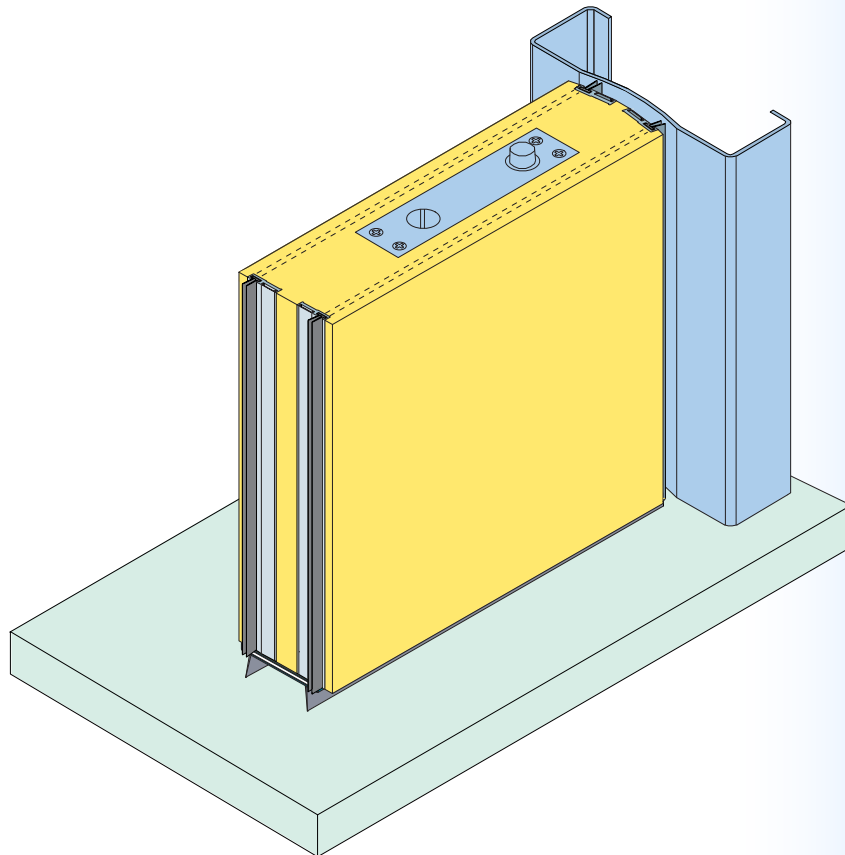

Please contact our office if you require any further information

NSW Ph: (02) 9907 3844 Fax: (02) 9907 3855

VIC Ph: (03) 9785 2688 Fax: (03) 9785 2386

QLD Ph: (07) 3635 5000 Fax: (07) 3861 9266

E-mail integrity@lorient.com.au

www.lorient.com.au

Datasheet D-SOL018-08/08. Other datasheets available on request. Copyright © 2008 Lorient Australia