



Smoke Sealing Solutions

Proprietary Smoke Door System (Tested to AS1530 Part 7)

Single Leaf / Single Swing

LE1515 / IS8010si

Description

LE1515 perimeter seal - high performance retrofit, curved-fin Batwing seal with proven smoke & acoustic performance.

IS8010si automatic door bottom seal - medium duty, fully-mortised automatic door bottom seal.

Application

This sealing combination suitable for typical fire engineered specifications where designated medium temperature smoke leakage rates are required to be met in accordance with AS1530 Part 7.

Medium Temperature Test Results (Corrected to STP)

Door Configuration / Pressure	Exposure Temp	Door Perimeter Tested	Leakage Rate (m ³ h) corrected to STP conditions @ a Pressure Differential of		
			10Pa	25Pa	50Pa
Opening Towards Positive Pressure (fire side)	Medium (200°C)	Entire Perimeter	< 2	< 2	< 2
Opening Towards Positive Pressure (fire side)	BCA Spec C3.4 Medium (200°C) > 30 minutes	Entire Perimeter	< 2	< 2	< 2

Note: The medium test with exposure times greater than 30 minutes is consistent with the BCA requirements of Specification C3.4 which requires doorsets to be resistant to smoke at 200°C for 30 minutes.

* Please contact Lorient for further details on this proprietary door assembly.

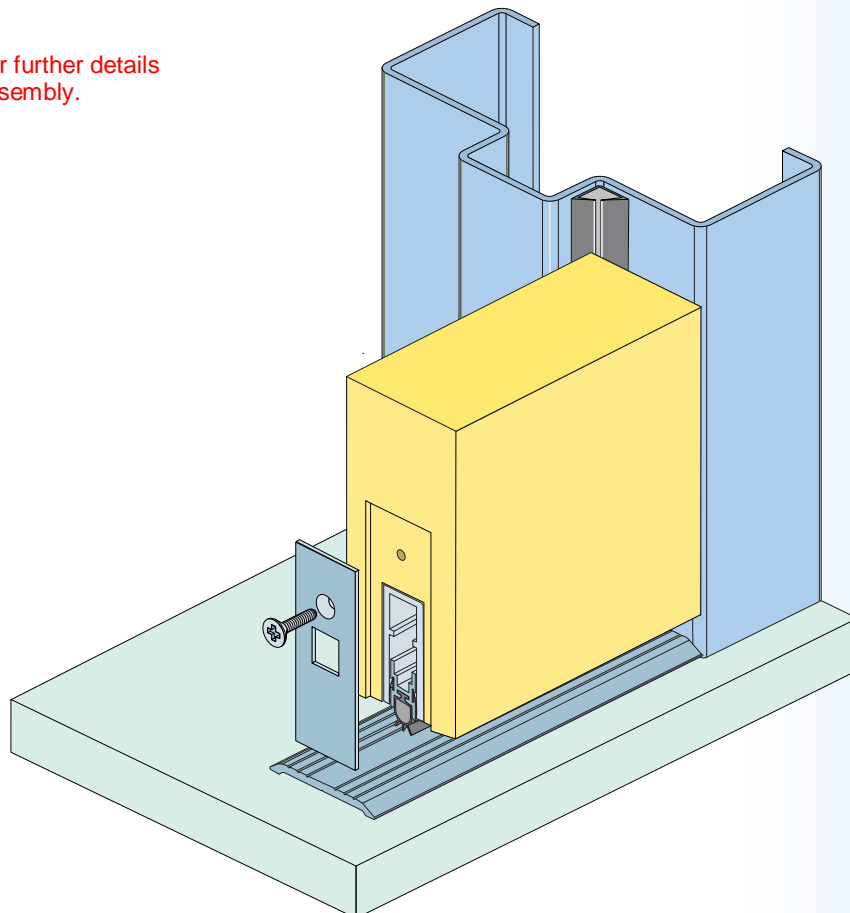

* Shown with an IS4130 threshold plate to provide an optimum sealing surface for door bottom seals.

Please contact our office if you require any further information

NSW Ph: (02) 9907 3844 Fax: (02) 9907 3855

VIC Ph: (03) 9785 2688 Fax: (03) 9785 2386

QLD Fax: (07) 3635 5000 Fax: (07) 3861 9266

E-mail integrity@lorient.com.au

www.lorient.com.au

Datasheet D-SOL009-08/08. Other datasheets available on request. Copyright © 2008 Lorient Australia